

TO-92 Plastic-Encapsulate Transistors

FEATURES

- Low $V_{CE(sat)}$
- Complementary Transistor with The 2SB1116
- TRANSISTOR (NPN)

MECHANICAL DATA

- Case style: TO-92 molded plastic
- Mounting position: any

TO-92

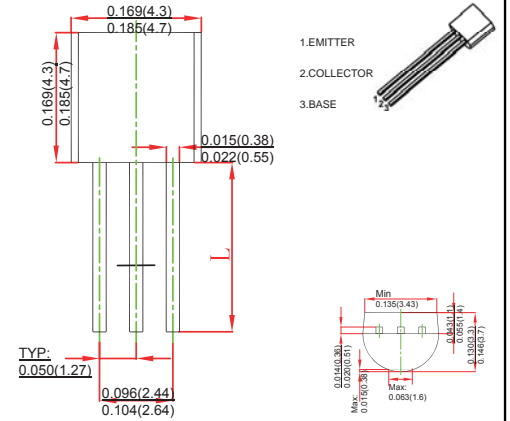

MAXIMUM RATINGS AND CHARACTERISTICS

@ 25°C Ambient Temperature (unless otherwise noted)

Symbol	Parameter	Value	Unit
V_{CBO}	Collector-Base Voltage	60	V
V_{CEO}	Collector-Emitter Voltage	50	V
V_{EBO}	Emitter-Base Voltage	6	V
I_C	Collector Current	1	A
P_C	Collector Power Dissipation	750	mW
$R_{\theta JA}$	Thermal Resistance From Junction To Ambient	166	°C/W
T_j	Junction Temperature	150	°C
T_{stg}	Storage Temperature	-55~+150	°C

ELECTRICAL CHARACTERISTICS $T_a=25^\circ\text{C}$ unless otherwise specified

Parameter	Symbol	Test conditions	Min	Typ	Max	Unit
Collector-base breakdown voltage	$V_{(BR)CBO}$	$I_C=0.01\text{mA}, I_E=0$	60			V
Collector-emitter breakdown voltage	$V_{(BR)CEO}$	$I_C=2\text{mA}, I_B=0$	50			V
Emitter-base breakdown voltage	$V_{(BR)EBO}$	$I_E=0.01\text{mA}, I_C=0$	6			V
Collector cut-off current	I_{CBO}	$V_{CB}=60\text{V}, I_E=0$			0.1	μA
Emitter cut-off current	I_{EBO}	$V_{EB}=6\text{V}, I_C=0$			0.1	μA
DC current gain	$h_{FE(1)}$ *	$V_{CE}=2\text{V}, I_C=100\text{mA}$	135		600	
	$h_{FE(2)}$ *	$V_{CE}=2\text{V}, I_C=1\text{A}$	81			
Collector-emitter saturation voltage	$V_{CE(sat)}$ *	$I_C=1\text{A}, I_B=50\text{mA}$			0.3	V
Base-emitter saturation voltage	$V_{BE(sat)}$ *	$I_C=1\text{A}, I_B=50\text{mA}$			1.2	V
Base-emitter voltage	V_{BE} *	$V_{CE}=2\text{V}, I_C=50\text{mA}$	0.6		0.7	V
Collector output capacitance	C_{ob}	$V_{CB}=10\text{V}, I_E=0, f=1\text{MHz}$			19	pF
Transition frequency	f_T	$V_{CE}=2\text{V}, I_C=100\text{mA}$	100			MHz

*Pulse test: pulse width $\leq 350\mu\text{s}$, duty cycle $\leq 2.0\%$.

CLASSIFICATION OF h_{FE}

RANK	L	K	U
RANGE	135-270	200-400	300-600