

## TO-220-3L Plastic-Encapsulate MOSFETS

### FEATURE

- High Current Rating
- Lower  $R_{DS(on)}$
- Lower Capacitance
- Lower Total Gate Charge
- Tighter VSD Specifications
- Avalanche Energy Specified
- 600V N-Channel Power MOSFET

### MECHANICAL DATA

- Case style: TO-220-3L molded plastic
- Mounting position: any

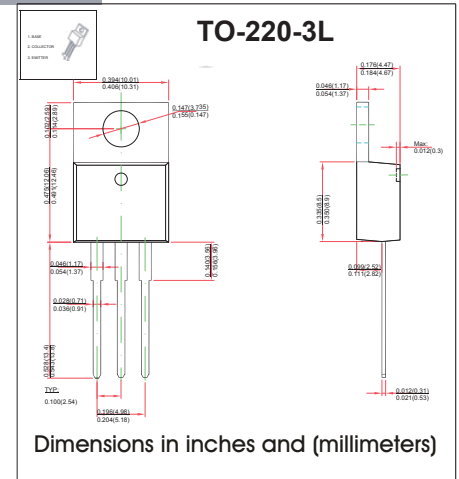

## MAXIMUM RATINGS AND CHARACTERISTICS

@ 25°C Ambient Temperature (unless otherwise noted)

Parameter	Symbol	Value	Units
Drain-Source Voltage	$V_{DS}$	600	V
Gate-Source Voltage	$V_{GS}$	$\pm 30$	
Continuous Drain Current	$I_D$	4.0	A
Continuous Drain-Source Diode Forward Current	$I_S$	4.0	
Single Pulsed Avalanche Energy (note1)	$E_{AS}$	260	mJ
Thermal Resistance from Junction to Ambient	$R_{\theta JA}$	62.5	°C/W
Operating and Storage Temperature Range	$T_J, T_{STG}$	-55 ~ +150	°C
Maximum lead temperature for soldering purposes, 1/8" from case for 5 seconds	$T_L$	260	

$V_{(BR)DSS}$	$R_{DS(on)MAX}$	$I_D$
600V	3Ω@10V	4A

## MOSFET ELECTRICAL CHARACTERISTICS $T_A=25^\circ\text{C}$ unless otherwise specified

Parameter	Symbol	Test Condition	Min	Typ	Max	Unit
<b>Off characteristics</b>						
Drain-source breakdown voltage	$V_{(BR)DSS}$	$V_{GS} = 0V, I_D = 250\mu A$	600			V
Drain-source diode forward voltage(note2)	$V_{SD}$	$V_{GS} = 0V, I_S = 4.0A$			1.5	
Zero gate voltage drain current	$I_{DSS}$	$V_{DS} = 600V, V_{GS} = 0V$			25	$\mu A$
Gate-body leakage current, forward(note2)	$I_{GSSF}$	$V_{DS} = 0V, V_{GS} = 30V$			100	nA
Gate-body leakage current, reverse(note2)	$I_{GSSR}$	$V_{DS} = 0V, V_{GS} = -30V$			-100	
<b>On characteristics (note2)</b>						
Gate-threshold voltage	$V_{GS(th)}$	$V_{DS} = V_{GS}, I_D = 250\mu A$	2.0	3.5	4.0	V
Static drain-source on-resistance	$R_{DS(on)}$	$V_{GS} = 10V, I_D = 2.0A$		1.8	3.0	Ω
Forward transconductance	$g_{fs}$	$V_{DS} = 50V, I_D = 2A$	2.0	2.6		S
<b>Dynamic characteristics (note 3)</b>						
Input capacitance	$C_{iss}$	$V_{DS} = 25V, V_{GS} = 0V, f = 1MHz$		540	760	pF
Output capacitance	$C_{oss}$		125	180		
Reverse transfer capacitance	$C_{rss}$		8.0	20		
<b>Switching characteristics</b>						
Total gate charge	$Q_g$	$V_{DS} = 480V, V_{GS} = 10V, I_D = 4.0A$		5.0	10	nC
Gate-source charge	$Q_{gs}$		2.7			
Gate-drain charge	$Q_{gd}$		2.0			
Turn-on delay time (note3)	$t_{d(on)}$	$V_{DD} = 300V, V_{GS} = 10V, R_G = 9.1\Omega, I_D = 4.0A$		12	20	ns
Turn-on rise time (note3)	$t_r$		7.0	10		
Turn-off delay time (note3)	$t_{d(off)}$		19	40		
Turn-off fall time (note3)	$t_f$		10	20		

### Notes :

1.  $L = 30mH, I_L = 4A, V_{DD} = 100V, V_{GS} = 10V, R_G = 25\Omega, \text{Starting } T_J = 25^\circ\text{C}.$
2. Pulse Test : Pulse width  $\leq 300\mu s$ , duty cycle  $\leq 2\%$ .
3. These parameters have no way to verify.

# RATINGS AND CHARACTERISTIC CURVES

